



Knockout Rod Extensions



Hex Style

Catalog Number	T	L Length	Thread internal & external
KRE37-10	1.052	1.672	3/8 - 16
KRE37-15	1.552	2.172	3/8 - 16
KRE50-10	1.052	1.672	1/2 - 13
KRE50-15	1.552	2.175	1/2 - 13
KRE62-10	1.052	1.922	5/8 - 11
KRE62-15	1.552	2.422	5/8 - 11
KRE75-10	1.052	1.672	3/4 - 10
KRE75-15	1.552	2.422	3/4 - 10
KRE75-10NT*	1.052	1.922	3/4 - 10
KRE75-15NT*	1.552	2.422	3/4 - 10

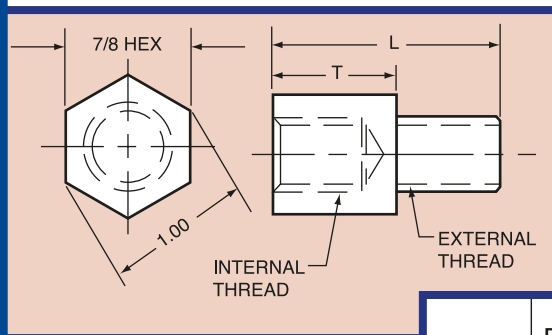

*Note: External thread only. Tool maker to machine internal thread on "NT" style.

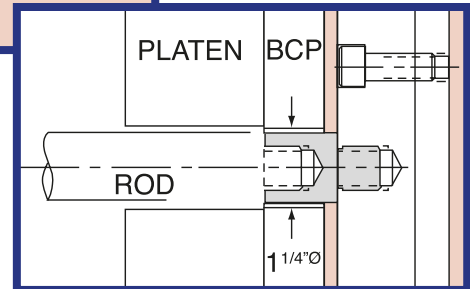

"L" DIMENSIONS:

1.052 = .875 (BCP) + .187 (Stop Pins) - .010
 1.552 = 1.375 (BCP) + .187 (Stop Pins) - .010

Round Style



Catalog Number	D	Thread
KR37-10	1.052	3/8 - 16
KR37-15	1.552	3/8 - 16
KR50-10	1.052	1/2 - 13
KR50-15	1.552	1/2 - 13
KR62-10	1.052	5/8 - 11
KR62-15	1.552	5/8 - 11
KR75-10	1.052	3/4 - 10
KR75-15	1.552	3/4 - 10
KR75-10NT*	1.052	no thread
KR75-15NT*	1.552	no thread

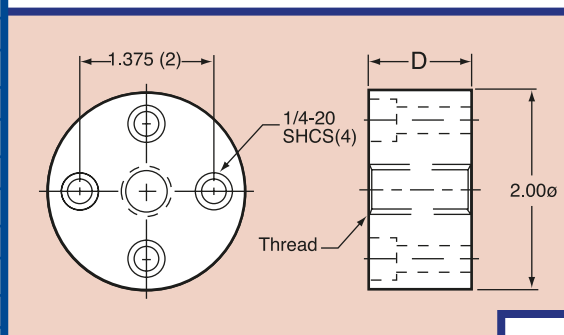

*Note: No female thread. Tool maker to machine internal thread on "NT" style.

